

USER MANUAL

ESP 32x10A / Cover / Cover Mix

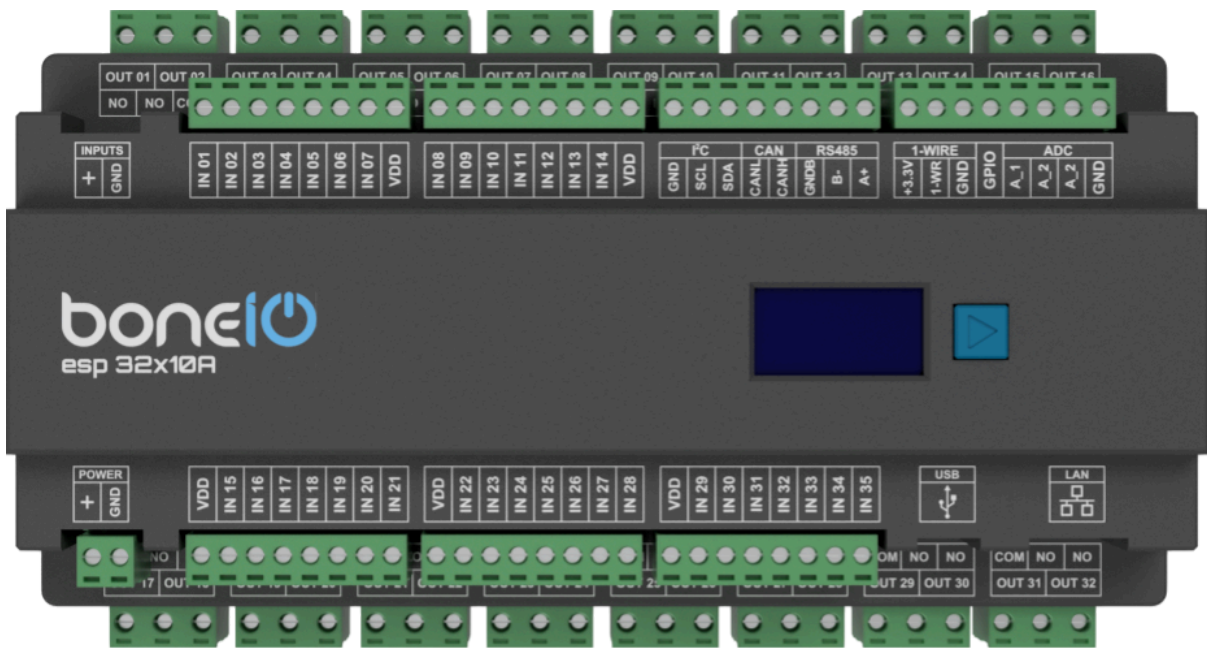

ENGLISH VERSION



READ BEFORE USE

This document contains important technical and safety information about the device, its safety use and installation.

⚠ CAUTION

Before beginning the installation, please read this instruction and any other documents included with the device carefully and completely. Failure to follow the installation procedures could lead to malfunction, danger to your health and life, violation of the law or refusal of legal and/or commercial guarantee (if any). boneIO is not responsible for any loss or damage in case of incorrect installation or improper operation of this device due to failure of following the user and safety instructions in this guide

⚠ CAUTION

Danger of electrocution. Mounting and Installation of the boneIO device to the power grid has to be performed with caution, by a qualified person (electrician).

⚠ CAUTION

Danger of electrocution. Every change in the connection of the terminals has to be done after ensuring all local power is powered off/disconnected.

⚠ CAUTION

The power supply that powers the boneIO device should be connected by protecting it with a differential switch and a circuit breaker. Each of the boneIO device outputs should be protected with a differential switch and a circuit breaker with a rated current lower than the rated current of the boneIO output.

Product information

boneIO ESP series are smart home controllers. There are 4 different versions of controllers:

- boneIO ESP 32x10A, which has 32 relays each 10A rated,
- boneIO Cover which has 32 relays, each 10A rated, paired together with hardware interlock to secure cover engine,
- boneIO Cover Mix, which has 32 relays, each 10A rated, half of outputs are paired together with hardware interlock to secure the cover engine,
- boneIO 24x16A which has 24 relays each 16A rated.

It is prepared to work with Esphome software onboard and be adopted into the Home Assistant smart home system.

Each device has:

- 35 digital inputs,
- buses: RS485/Modbus, CAN, 1-wire, I²C,
- 3 ADC inputs,
- 1 GPIO,
- Ethernet 10/100Mbps,
- USB-C port (designed for software uploads).

Power up device

To power boneIO up connect power supply 24VDC to POWER socket. Look for proper polarity of + and GND!

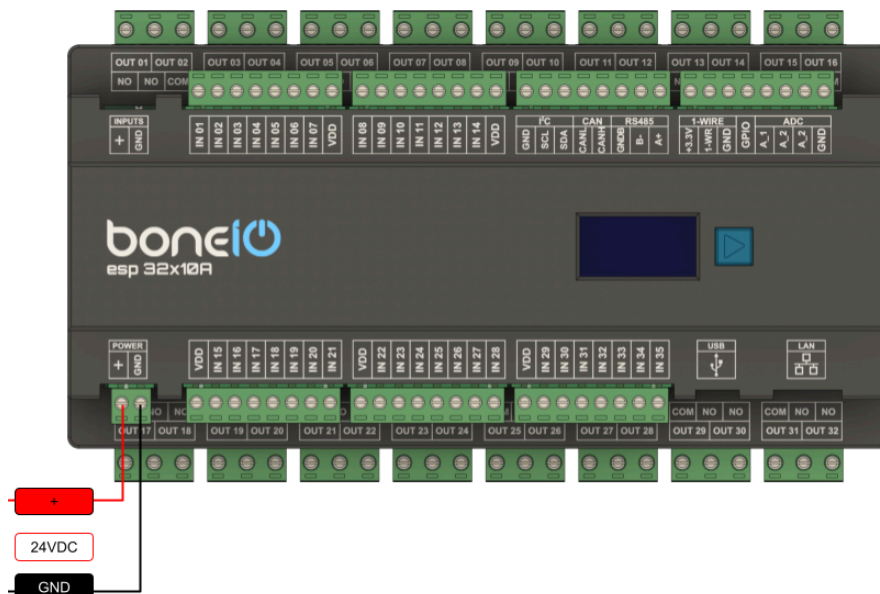

Connecting Ethernet

Connect Ethernet cable to LAN port. By default IP address would be obtained via DHCP.

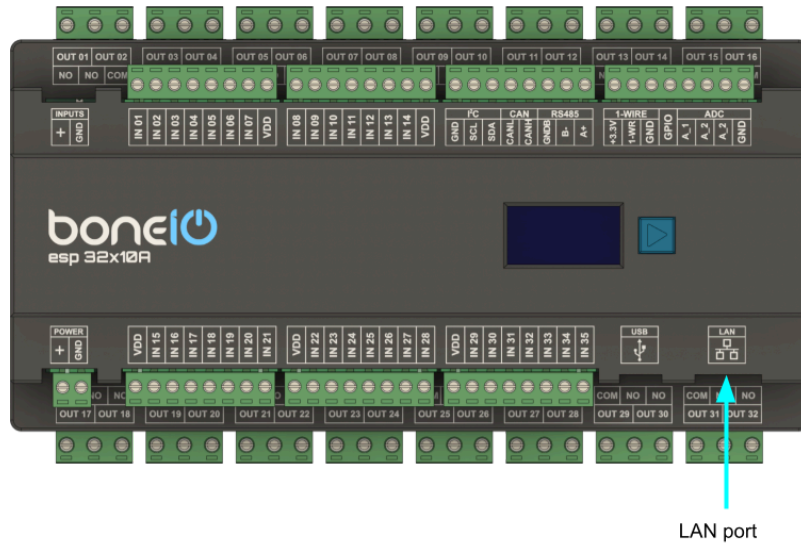

Connecting Inputs

The operation of digital inputs is based on applying the GND or VCC of the power supply to the IN_01 to IN_35 pin. User select the way of input triggering by setting Inputs switch. Input is triggered when the IN pin is connected with VDD pin. For more examples see:

<https://boneio.eu/docs/hardware/esp/v07#connecting-input>

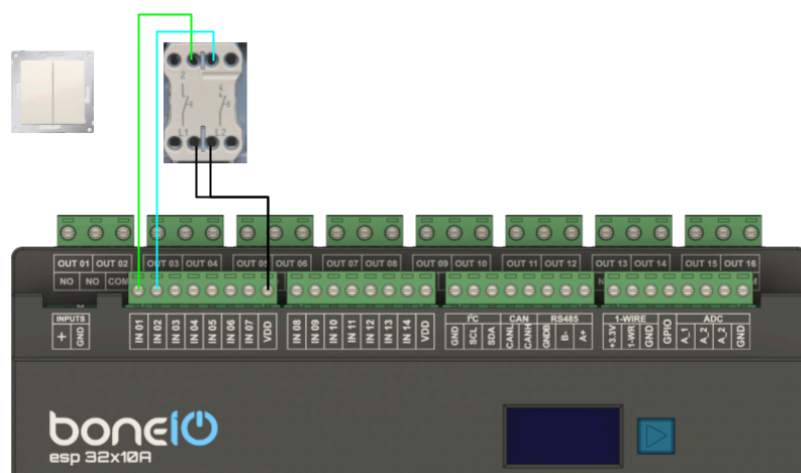

Connecting push button.

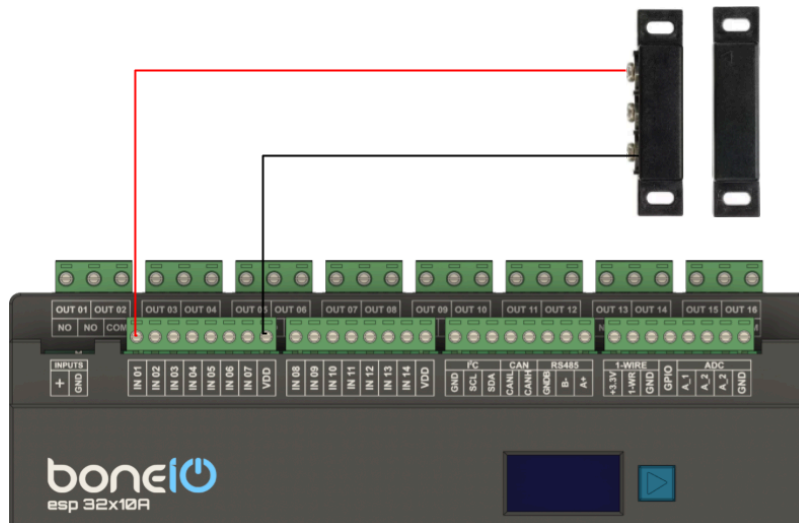

Connecting reed switch.

Connecting outputs

Each 2 outputs share one COM port. This is the input of the power source.

To connect light to OUT 01 connect L (power AC) to COM port of OUT 01, OUT_02 connectors.

For each pair you can plug in a different source of power.

More connecting examples are available at:

<https://boneio.eu/docs/hardware/esp/v07#connecting-outputs>

Examples has also Esphome code snippets to modify entities visible in Home Assistant.

The figure below shows how to connect Lights on 2 phases.

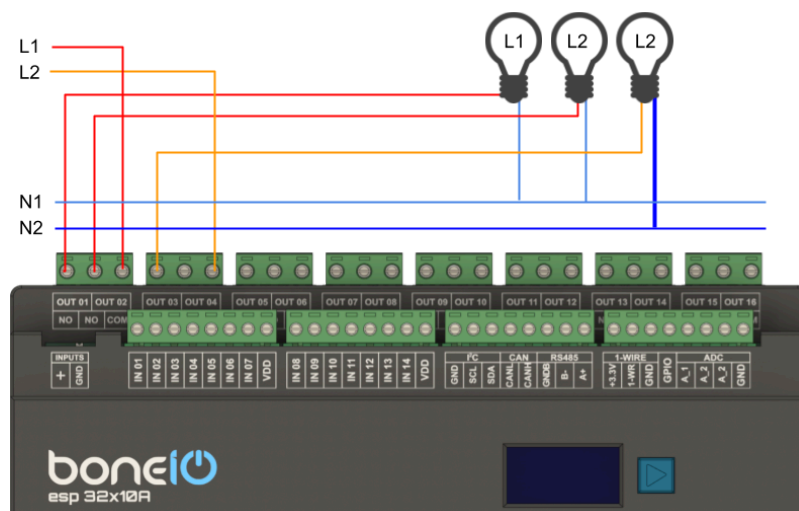

Connecting cover

Applies to boneIO Cover or boneIO Cover Mix

Each 2 outputs share one COM port. 2 ports have hardware interlock which block from turning them on simultaneously. Connect L power to COM port. Then connect UP output together with UP input of the cover motor and DOWN output with DOWN input of the motor.

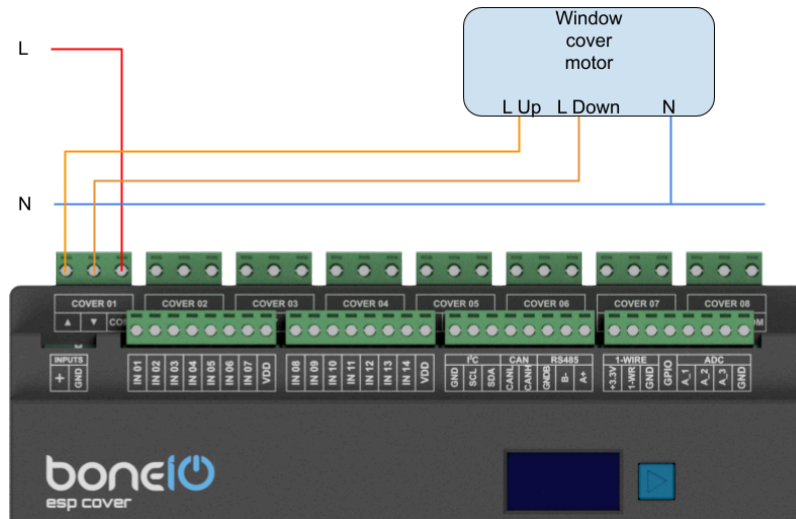

Connecting RS485 device

To use RS485/Modbus devices you have to connect A+ and B- cables to your Modbus client device.

In most cases GNDB is not needed. To configure it please follow our online instruction, Esphome documentation and follow your Modbus client device guide.

The maximum length of cable is 30m.

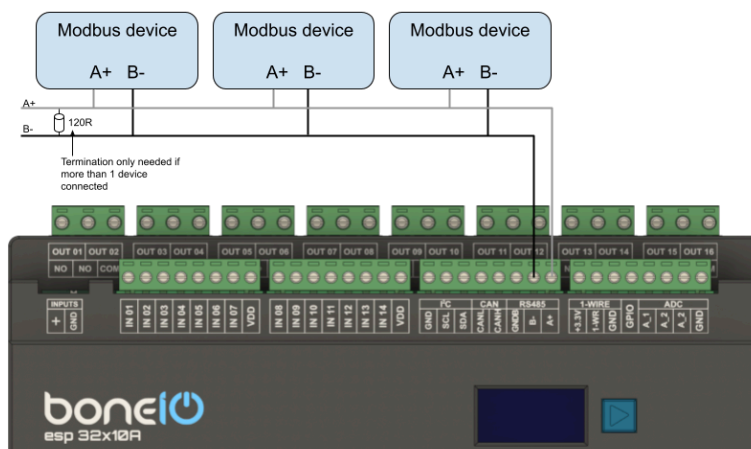

Connecting CAN

In order to connect CAN devices to CAN bus connect boneIO CAN H and CAN L with CAN H and CAN L of the other devices. Maximum cable length is 30m.

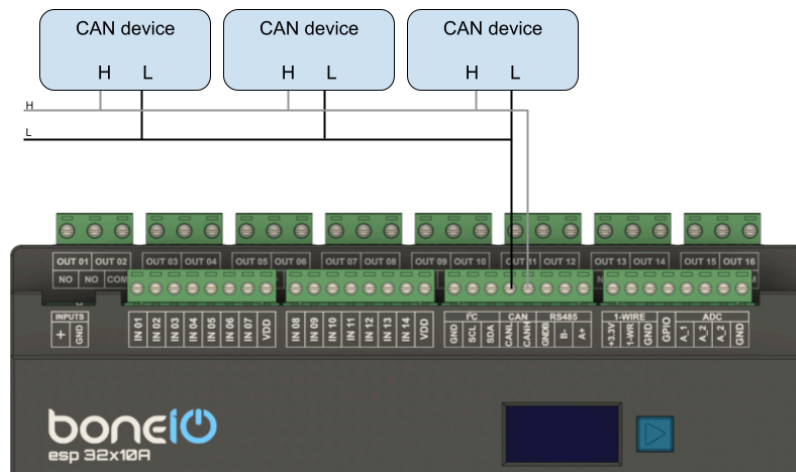

Connecting 1-wire

To connect 1 wire device you have to connect them in bus topology. Follow the diagram to connect it properly. By default boneIO has a 4.7k pull-up resistor to +3.3 on 1-wire bus.

The maximum summary length of the bus cable is 20m.

The number of devices depends on the quality of cables and connection.

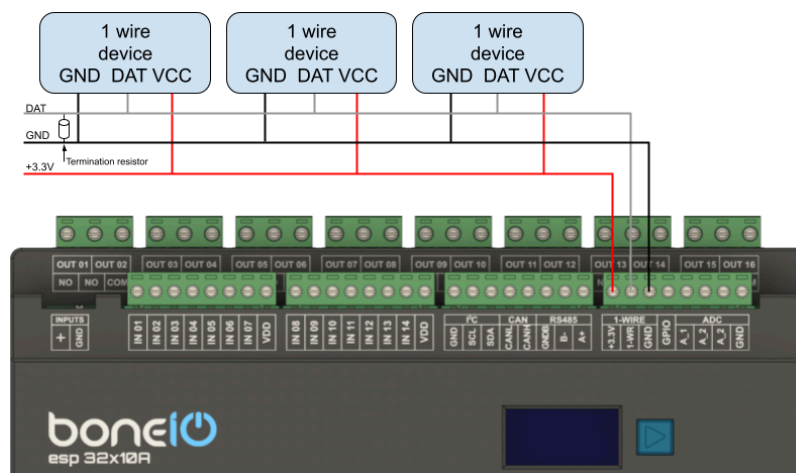

Connecting ADC

boneIO has 3 analog inputs for measurement of sensor values.

- A_1 can measure 0-5V,
- A_2 can measure 0-10V,
- A_3 can measure 0-25V.

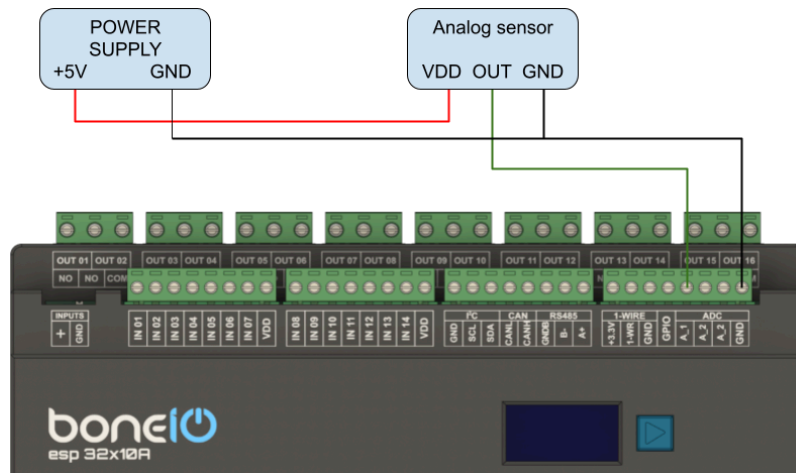

Switching input control +/-GND

The operation of digital inputs is based on applying the GND or VCC of the power supply to the IN_01 to IN_35 pin. The user selects the way of input triggering by switching the input settings. Setting the Inputs switch to the + position will cause a voltage of 24VDC to appear on the VDD connectors, and if set to the GND position, a GND will appear on the VDD connector.

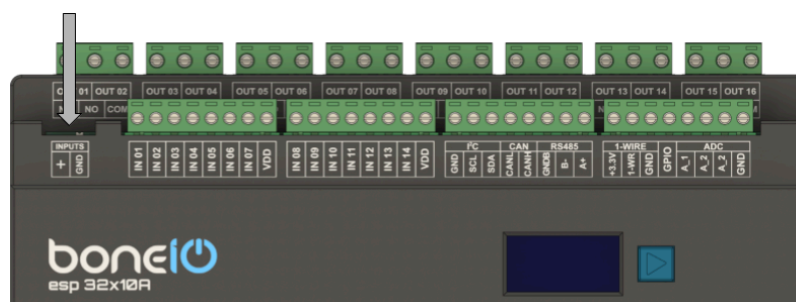

OLED operating

The OLED display shows statistics about the boneIO device.

It can display IP address, device name, uptime, current temperature and current power consumption of the controller.

In order to wake up or switch screens click the blue button on the right side of the boneIO device.

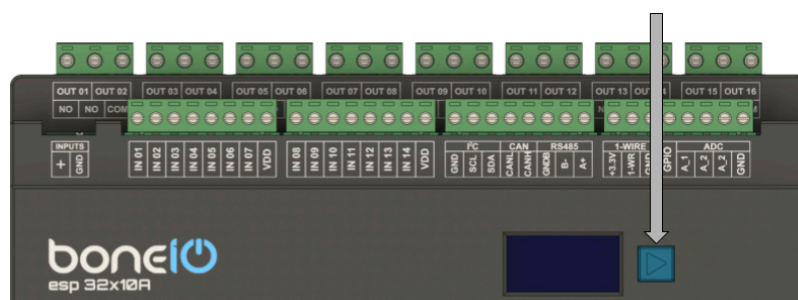

boneIO power measurement

boneIO has installed a power measurement tool onboard.

It can measure power consumption of the device. It's preconfigured already.

Users can see power measurement on the OLED display or in HomeAssistant statistics.

Software installation

boneIO ESP is compatible with the Made for Esphome program. It is provided with Esphome software by default. Device should auto adopt itself in Esphome addon and should be autodiscovered in Home Assistant if network allows mDNS packets.

We recommend adopting the device in the Esphome addon first, configure it and then add it to the Home Assistant.

There might be newer version of Esphome firmware available at <https://boneio.eu/esp>

More detailed and up to date instructions are available at the documentation part of our website. https://boneio.eu/docs/esphome/esphome_boneio_adopt

Documentation of specific configuration is available at:

<https://boneio.eu/docs/hardware/esp/current>

Technical data

Power supply	24VDC
Power consumption	2W-18W
Number of digital inputs	35
Inputs voltage	24VDC
Number of outputs	32
Max output voltage	230VAC 30VDC
Max output current	10A
Analog Inputs	3
External interfaces	Modbus RS485, I2C bus, 1-wire, CAN (for future use)
Communication	Ethernet 10/100Mbit USB-C (firmware installation)
Dimensions	216mm x 106mm x 57mm (WxHxL) (without plugs) 216mm x 123mm x 57mm (WxHxL) (with plugs) 12DIN
Weight	800g



Made in Poland
boneIO Sp. z o.o.
Aleja Tadeusza Kościuszki 101,
90-441 Łódź, Polska

Discord support:
<https://discord.gg/Hm2CzSjvtu>

