

USER MANUAL

Black 32x10A / Cover / Cover Mix

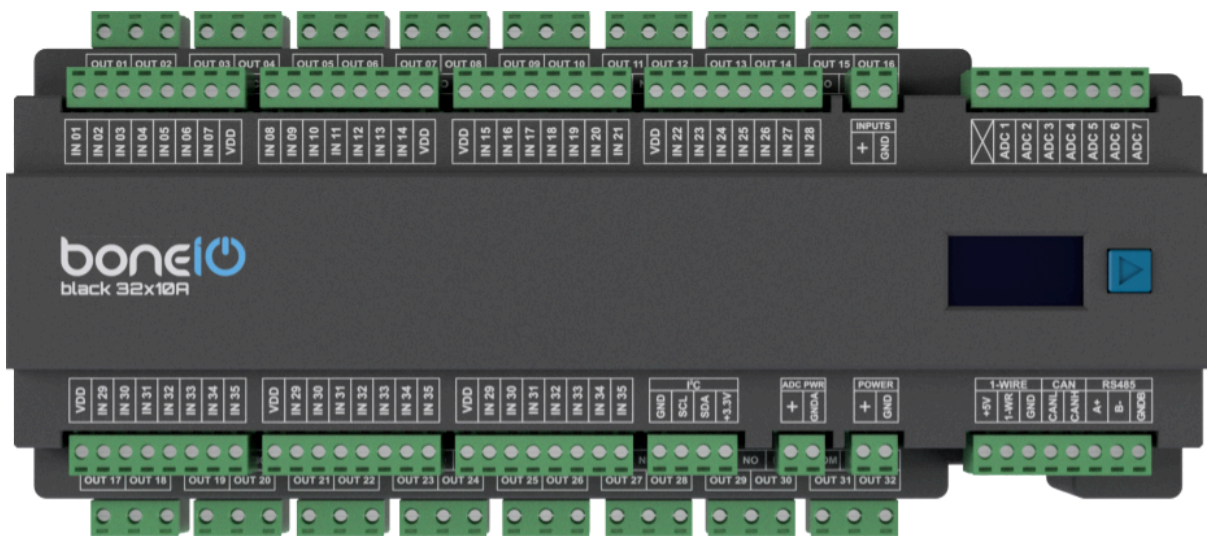

ENGLISH VERSION



READ BEFORE USE

This document contains important technical and safety information about the device, its safety use and installation.

⚠ CAUTION

Before beginning the installation, please read this instruction and any other documents accompanying the device carefully and completely. Failure to follow the installation procedures could lead to malfunction, danger to your health and life, violation of the law or refusal of legal and/or commercial guarantee (if any). boneIO is not responsible for any loss or damage in case of incorrect installation or improper operation of this device due to failure of following the user and safety instructions in this guide

⚠ CAUTION

Danger of electrocution. Mounting and Installation of the boneIO device to the power grid has to be performed with caution, by a qualified person (electrician).

⚠ CAUTION

Danger of electrocution. Every change in the connection of the terminals has to be done after ensuring all local power is powered off/disconnected.

⚠ CAUTION

The power supply that powers the boneIO device should be connected by protecting it with a differential switch and a circuit breaker. Each of the boneIO device outputs should be protected with a differential switch and a circuit breaker with a rated current lower than the rated current of the boneIO output.

Product information

bonelO Black series are smart home controllers. There are 4 different versions of controllers:

- bonelO Black 32x10A, which has 32 relays each 10A rated,
- bonelO Black Cover which has 32 relays, each 10A rated, paired together with hardware interlock to secure cover engine,
- bonelO Black Cover Mix, which has 32 relays, each 10A rated, half of outputs are paired together with hardware interlock to secure the cover engine,
- bonelO Black 24x16A which has 24 relays each 16A rated.

It is prepared to work with our open source bonelO application, which communicates through MQTT protocol. It's specially prepared for Home Assistant. If Home Assistant has MQTT integration configured, then it could be auto adopted into the Home Assistant smart home system.

Each device has:

- 49 digital inputs,
- buses: RS485/Modbus, CAN, 1-wire, I²C,
- 7 ADC inputs, directly attached to the on board PC,
- Ethernet 10/100Mbps,
- mini USB port and micro SD Card slot.

Power up device

To power bonelO up connect power supply 24VDC to POWER socket. Look for proper polarity of + and GND!

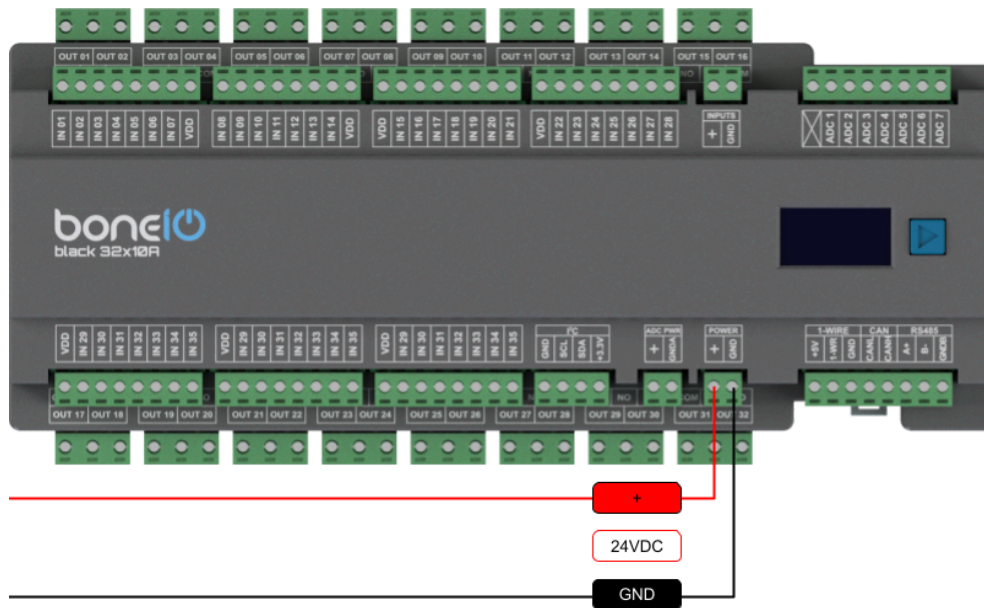

Connecting Ethernet

Connect Ethernet cable to LAN port. It's under the CAN bus connector. By default IP address would be obtained via DHCP.

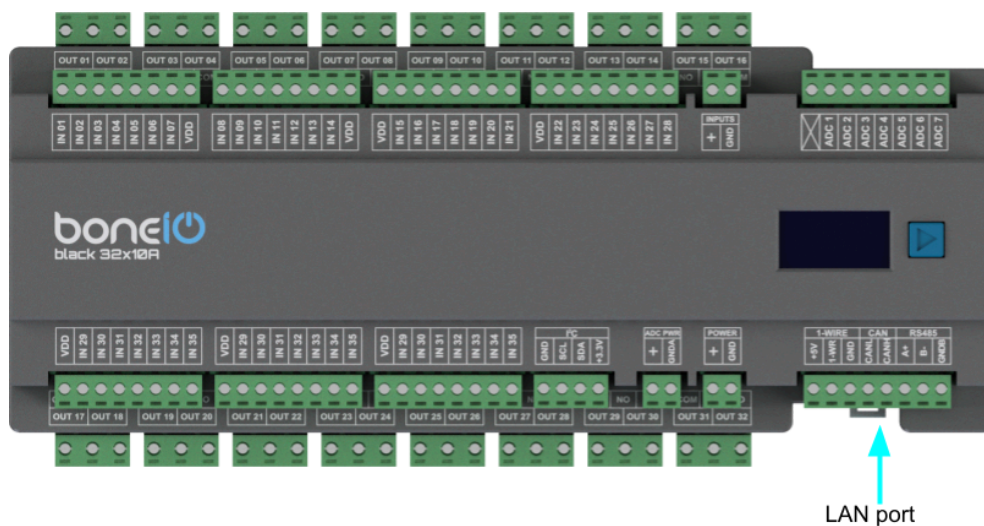

Connecting Inputs

The operation of digital inputs is based on applying the GND or VCC of the power supply to the IN_01 to IN_49 pin. User select the way of input triggering by setting Inputs switch. Input is triggered when the IN pin is connected with VDD pin.

Some inputs can't be pushed down during boot of boneIO Black. The best option would be to only use them for push buttons: IN 01, IN 02, IN 09, IN 10, IN 19, IN 20, IN 21.

Inputs can detect pressed/released states or single, double and long clicks.
 For the first one use binary sensors in configuration, for second event entities.
 Software configuration:

- <https://boneio.eu/docs/black/configuration/binary>
- <https://boneio.eu/docs/black/configuration/event>

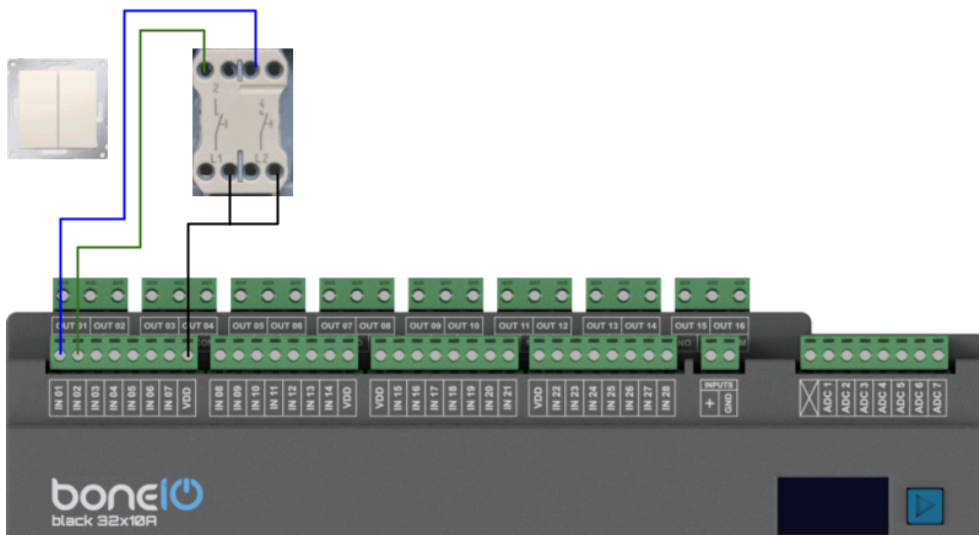

Connecting push button.

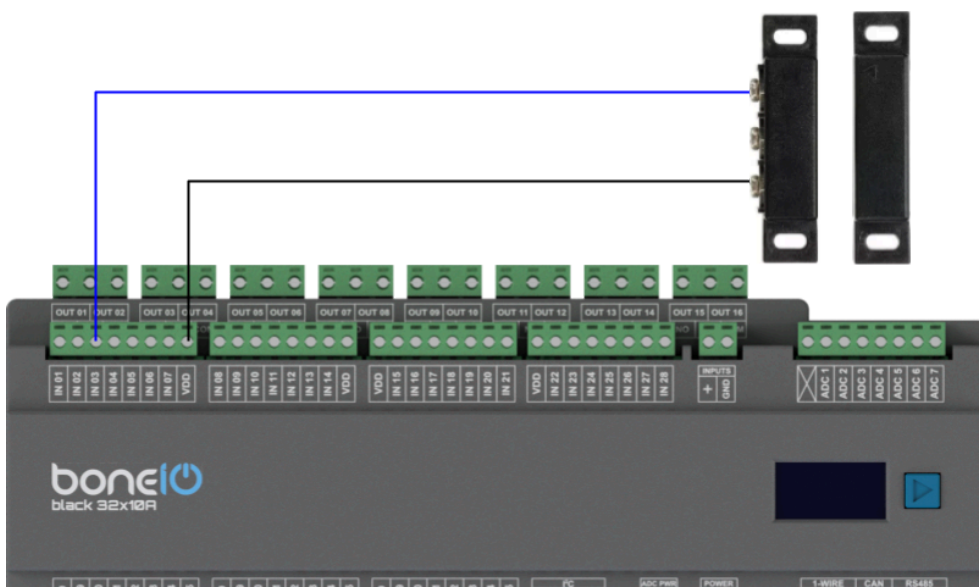

Connecting reed switch.

Connecting outputs

Each 2 outputs share one COM port. This is the input of the power source.

To connect light to OUT 01 connect L (power AC) to COM port of OUT 01, OUT_02 connectors. For each pair you can plug in a different source of power.

The figure below shows how to connect Lights on 2 phases.

Software configuration: <https://boneio.eu/docs/black/configuration/output>

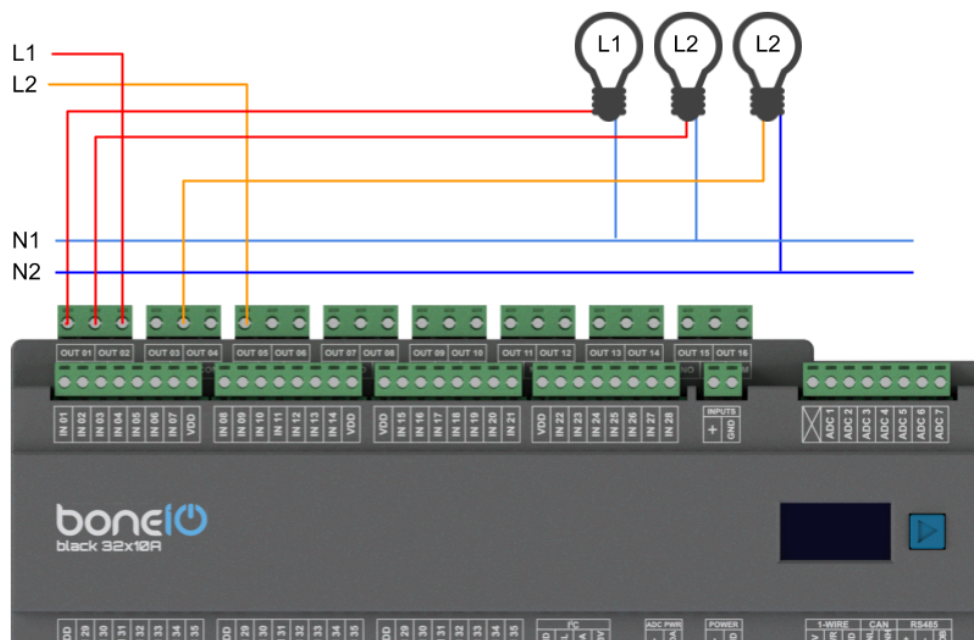

Connecting cover

Applies to boneiO Black Cover and boneiO Black Cover Mix

Each 2 outputs share one COM port. 2 ports have hardware interlock which block from turning them on simultaneously. Connect L power to COM port. Then connect UP output together with UP input of the cover motor and DOWN output with DOWN input of the motor. boneiO Black version doesn't support venetian blinds.

Configuration needs to use `boneio:` tag. Follow software documentation of cover component to make it work: <https://boneio.eu/docs/black/configuration/cover>

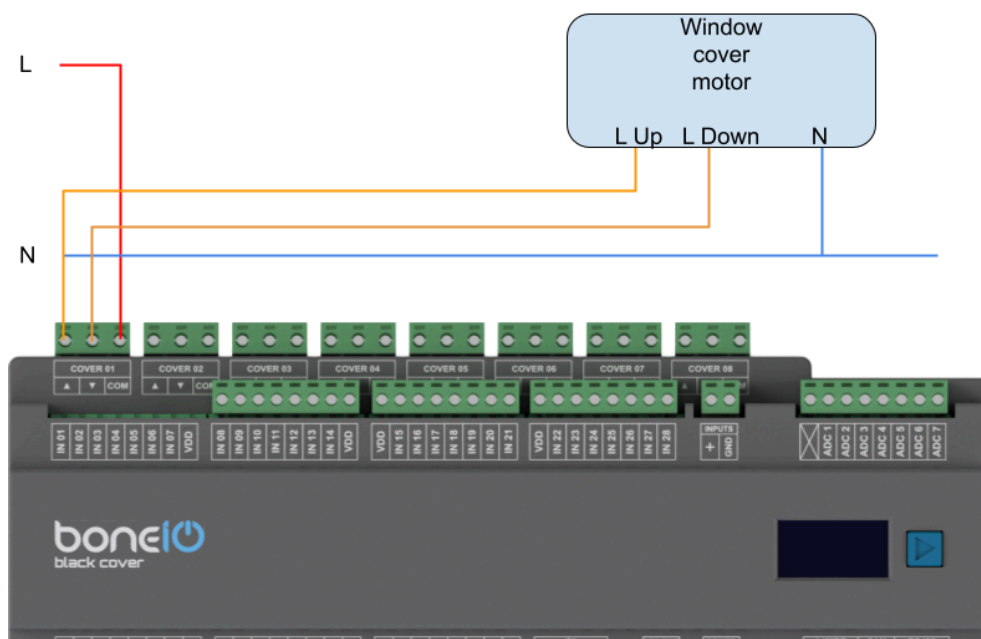

Connecting RS485 device

To use RS485/Modbus devices you have to connect A+ and B- cables to your Modbus client device.

In most cases GNDB is not needed. The maximum length of cable is 30m.

BoneIO Black currently supports only fetching sensor values. It cannot send commands from Home Assistant. It might change in the future.

boneIO Black has builtin support for multiple sensors like energy meters, water meters, temperature and humidity sensors. For full list of supported devices look here:

<https://boneio.eu/docs/black/configuration/modbus-sensors>

If you have a Modbus device for which you have protocol documentation we'd be happy to add support for it. Contact us on Discord.

Software configuration: <https://boneio.eu/docs/black/configuration/modbus-sensors>

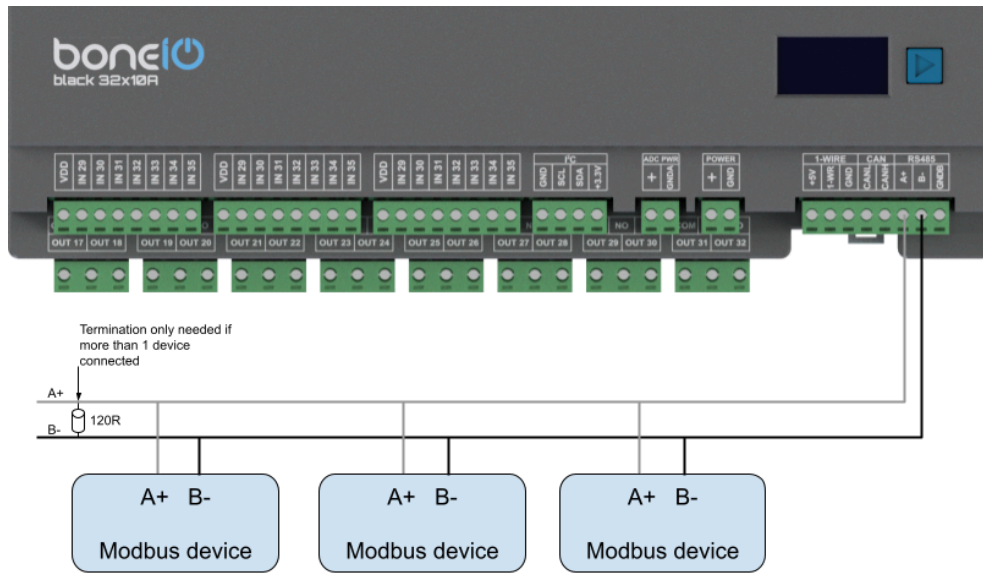

Connecting CAN

In order to connect CAN devices to CAN bus connect boneIO CAN H and CAN L with CAN H and CAN L of the other devices. Maximum cable length is 30m. CAN is currently not supported by boneIO software.

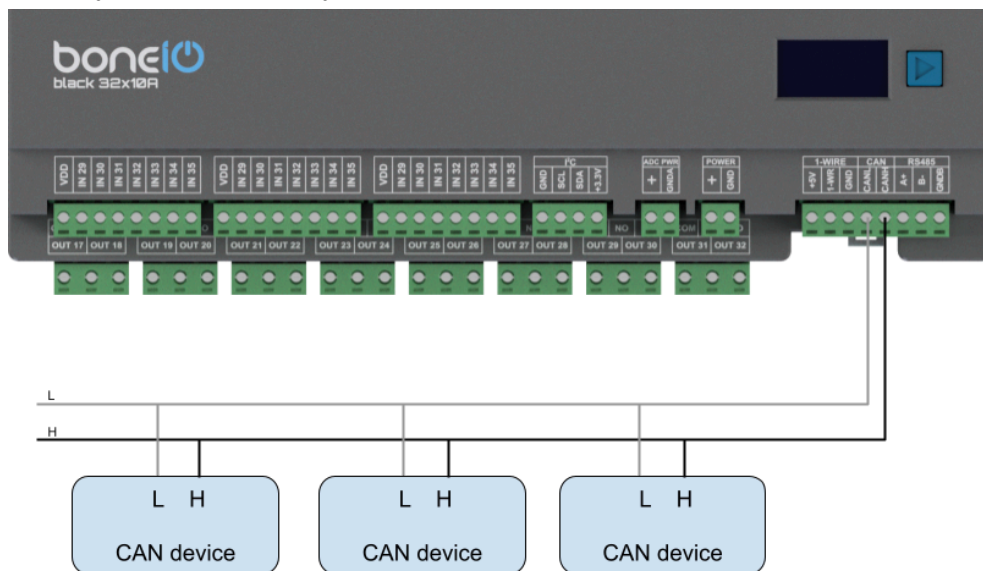

Connecting 1-wire

To connect 1 wire device you have to connect them in bus topology. Follow the diagram to connect it properly. By default boneIO has a 4.7k pull-up resistor to +3.3 on 1-wire bus.

The maximum summary length of the bus cable is 20m.

Number of devices depends on the quality of cables and connection.

Software configuration: <https://boneio.eu/docs/black/configuration/dallas>

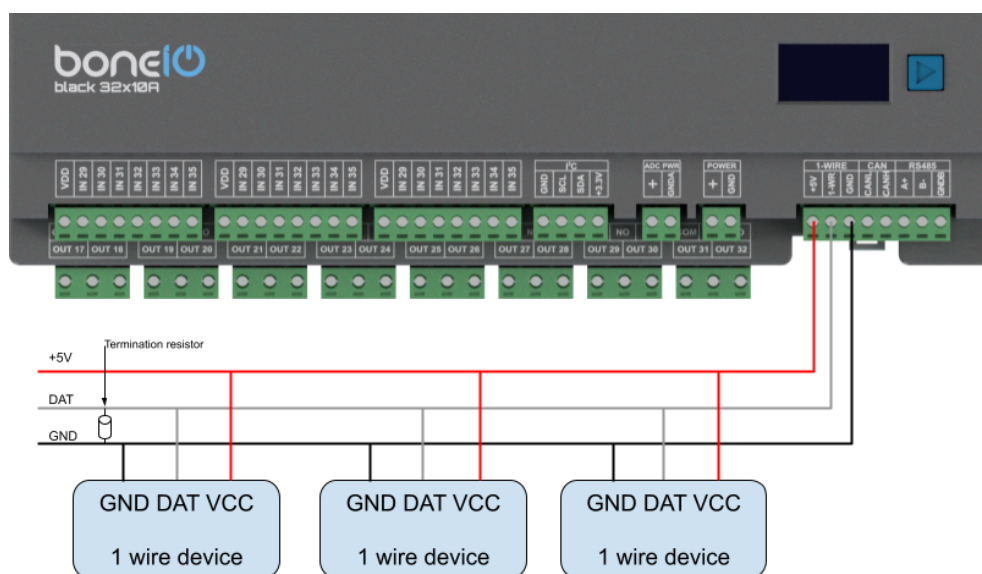

Connecting ADC

boneIO Black has 7 analog, which are directly derived from Beaglebone Black. The values range from 0 V (GND_ADC) - 1.8 V (VDD_ADC). Voltage higher than 1.8V will damage the board! You have to make a voltage divider to make it work. Then follow software configuration page to make it work: <https://boneio.eu/docs/black/configuration/adc>

It's highly not recommended to configure ADC pins in software without anything connected!

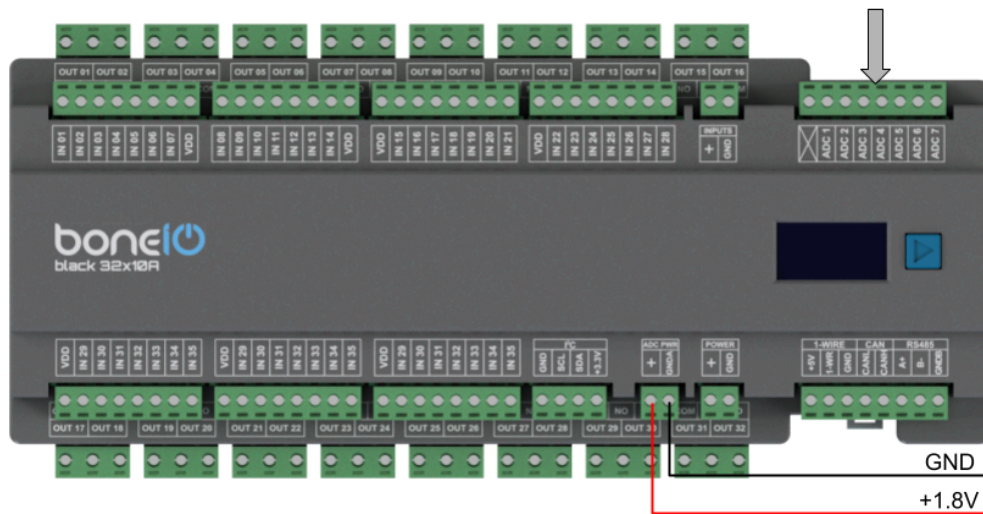

Switching input control +/-GND

The operation of digital inputs is based on applying the GND or VCC of the power supply to the IN_01 to IN_49 pin. The user selects the way of input triggering by switching the input settings. Setting the Inputs switch to the + position will cause a voltage of 24VDC to appear on the VDD connectors, and if set to the GND position, a GND will appear on the VDD connector.

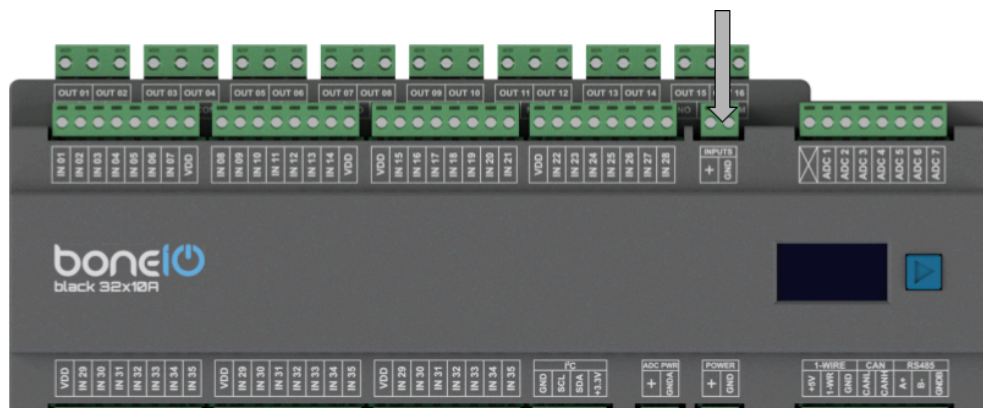

OLED operating

The OLED display shows statistics about the boneIO device. It can display IP address, device name, uptime, current temperature and current power consumption of the controller, output states, input states, link to web ui and states of the sensors attached to the device. In order to wake up or switch screens press the blue button on the right side of the boneIO device.

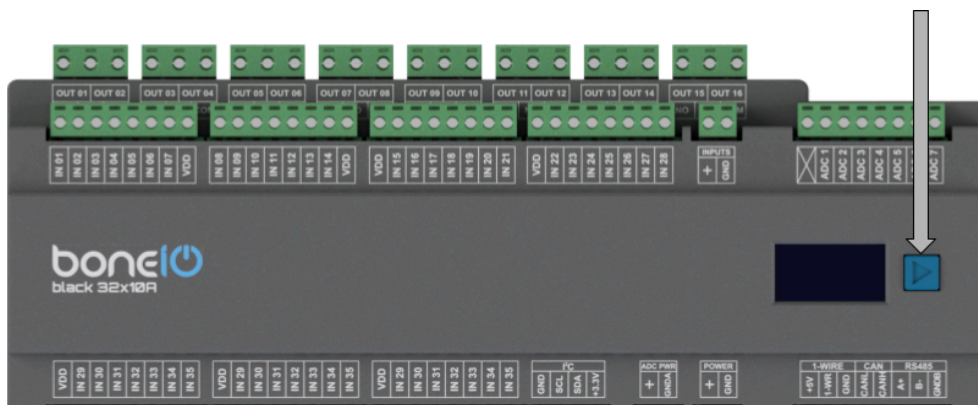

boneIO power measurement

boneIO has installed a power measurement tool onboard.

It can measure power consumption of the device.

Users can see power measurement on the OLED display or in HomeAssistant statistics.

Software installation

boneIO Black has Beaglebone Black mini PC inside.

It comes with Debian 10 onboard, MQTT (Mosquitto) broker installed and boneIO app with configured: inputs, outputs, onboard sensors, OLED screen and web ui.

The boneIO app uses yaml syntax for configuration.

It is prepared to be used by Home Assistant. It supports auto discovery through MQTT integration.

There might be newer version of our app available.

Check out version on our GitHub page: https://github.com/boneIO-eu/app_black/releases

Procedure of the upgrade is always up to date on our website:

<https://boneio.eu/docs/black/install/update>

Technical data

Power supply	24VDC
Power consumption	2W-18W
Number of digital inputs	49
Inputs voltage	24VDC
Number of outputs	32
Max output voltage	230VAC 30VDC
Max output current	10A
Analog Inputs	7
External interfaces	Modbus RS485, I2C bus, 1-wire, CAN (for future use)
Communication	Ethernet 10/100Mbit miniUSB Host
Dimensions	270 mm x 106 mm x 57 mm (WxHxL) (without plugs) 270 mm x 123 mm x 57 mm (WxHxL) (with plugs) 15DIN
Weight	900g



Made in Poland
bonelO Sp. z o.o.
Aleja Tadeusza Kościuszki 101,
90-441 Łódź, Polska

Discord support:
<https://discord.gg/Hm2CzSjvtu>

